

Oxygen sensors



Figure 1. Bosch oxygen sensor.

The first oxygen sensor developed by Bosch was installed in a Volvo 240/260 series vehicle 25 years ago.

Bosch delivered 10 million oxygen sensors to the U.S. market in 1976 and by 1983 the number had risen to 50 million. Today, Bosch produces 33 million oxygen sensors per year.

In 1982 Bosch launched the heated oxygen sensor which reaches full operability in 30 seconds after a cold engine is started. The sensor is heated to 400 °C and has a service life of 160,000 km, twice as long as the previous unheated sensor.

In 1994 Bosch developed an oxygen sensor with a planar ceramic structure that is fully functioning 10 seconds after the vehicle is started.

Today's oxygen sensor

Oxygen sensors (see Figure 1) are required today due to the increasingly tough exhaust emissions and go hand-in-hand with the catalytic converters. One oxygen sensor is used in the exhaust branch right before the catalytic converter. Sometimes a second oxygen sensor is placed in the exhaust system after the catalytic converter of a spark-ignition engine to permit optimum performance of the three-way catalytic converters.

The information obtained from the sensors indicates how complete the combustion process is in the combustion chamber. The optimum readings are obtained when the air to fuel ratio is 14.7 to one. The stoichiometric air/fuel ratio is the mass of 14.7 kg of air to 1 kg of gasoline theoretically necessary for complete combustion. The excess air factor or air ratio (λ) indicates the deviation of the actual air/fuel ratio from the theoretically required ratio. $\lambda = (\text{actual induced air mass}) / (\text{theoretical air requirement})$.

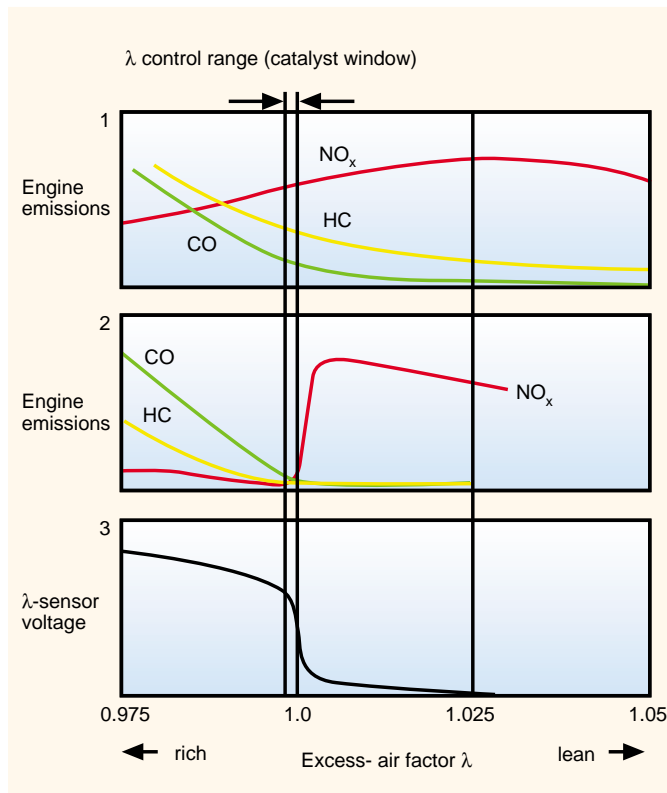

Figure 2. Control range and reductions in exhaust under three scenarios. Number 1 is without a catalytic converter. Number 2 is with a catalytic converter. Number 3 is the λ oxygen sensor voltage curve.

1. Ceramic coating
2. Electrodes
3. Contacts
4. Housing contacts
5. Exhaust pipe
6. Ceramic support shield (porous)
7. Exhaust gas
8. Ambient air

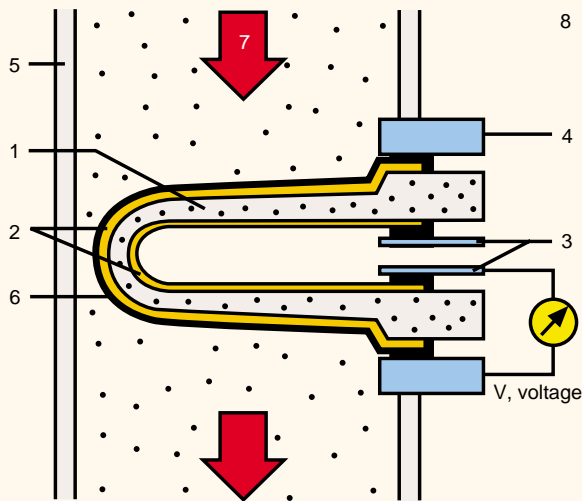

Figure 3. Oxygen sensor in exhaust pipe.

1. Porous protective layer
2. External electrode
3. Sensor laminate
4. Internal electrode
5. Reference air laminate
6. Insulation layer
7. Heater
8. Heater laminate
9. Connection contacts

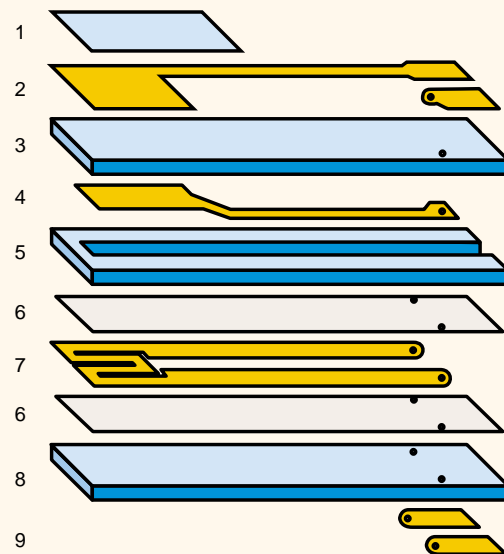

Figure 6. Operational layers in a planar oxygen sensor.

Variations from this optimum ratio result in various levels of emissions. Excess fuel results in the formation of hydrocarbons (HC) and carbon monoxide (CO). Excess air can cause increased levels of nitrogen oxides (NOx). The oxygen sensor or sensors can identify any variations from the ideal air/fuel ratio and send a signal to the engine management system to adjust the ignition and injection processes.

The three way catalytic converter is able to reduce the HC, CO, and NOx emissions by more than 98% provided the engine operates within a very narrow scatter range (<1%) centered around the stoichiometric air/fuel ratio (see Figure 2). A closed loop control system that relies on a closed loop control circuit to maintain the air/fuel mixture consistently within the optimal range known as the catalyst window is the best strategy.

1. Sensor housing
2. Ceramic support tube
3. Connection wire
4. Guard tube with slots
5. Active ceramic sensor layer
6. Contact
7. Protective cap
8. Heater element
9. Crimped connections for heater element
10. Spring washer

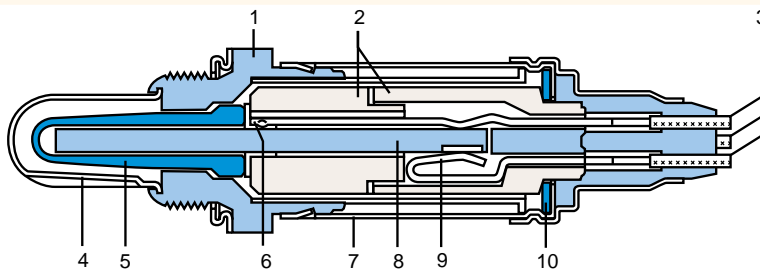

Figure 4. Heated oxygen sensor.

1. Guard tube
2. Ceramic seal assembly
3. Sensor housing
4. Ceramic support tube
5. Planar sensor element
6. Protective cap
7. Connection wire

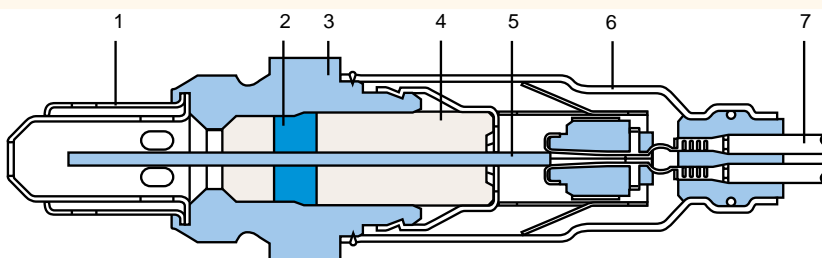

Figure 5. Planar oxygen sensor

Sensor design

The oxygen sensor (see Figure 3) is a galvanic oxygen concentration cell with a solid state electrolyte. The solid state electrolyte is an impermeable zirconium dioxide ceramic unit stabilized with yttrium oxide. It is open on one end and closed on the other. Mounted on both the inner and outer surfaces are gas permeable platinum electrodes.

The platinum electrode on the outside acts as a miniature catalyst to support reactions in the incoming exhaust gases and bring them into a state of stoichiometric balance. The side that is exposed to the exhaust gases also has a porous ceramic layer (Spinell coating) to protect against contamination. A metal tube with numerous slots guards the ceramic body against impacts and thermal shocks. The inner cavity is open to the atmosphere which serves as the unit's reference gas.

The two-state sensor operation is based in the Nernst Principle. The sensor's ceramic material conducts oxygen ions at temperatures 350°C and above. Disparities in oxygen levels on the respective sides of the sensor will result in the generation of

electrical voltage between the two surfaces. This voltage serves as the index of how much the oxygen levels vary on the two sides of the sensor. The amount of residual oxygen in the exhaust fluctuates sharply in response to the variation in the induction mixture's air/fuel ratio.

Oxygen sensitive voltage generation ranges from 800 to 1000 millivolts for rich mixtures to as low as 100 millivolts for lean mixtures. The transition from rich to lean corresponds to 450 to 500 millivolts.

Heated oxygen sensor

An electric heater element (see Figure 4) is used to warm the ceramic material when the engine is operating at low load factors. At the higher load factors the sensor's temperature is determined by the exhaust gas. The heated oxygen sensor helps ensure low and stable emissions due to the consistent maintenance of optimal operating temperatures.

Planar λ oxygen sensor

The basic operating concept (see Figure 5) is the same as the heated finger- type sensor in that it generates a response curve with a characteristic jump at λ equal to one. The planar sensor is distinguished from the finger type by:

- the solid body electrolyte consists of ceramic layers
- a solid ceramic sealant retains the sensor element within the sensor casting
- a dual-wall guard tube protects the sensor element against excessive thermal and physical stresses

The individual active layers (see Figure 6) are manufactured using silk-screening techniques. Stacking laminated layers with various configurations makes it possible to integrate a heater within the sensor element.

Wide band λ oxygen sensor

This sensor expands on the principle of the Nernst unit (two-state sensor function) by incorporating a second chamber, the pump cell (see Figure 7). It is through this small slot in this pump cell that the exhaust gas enters the actual monitoring

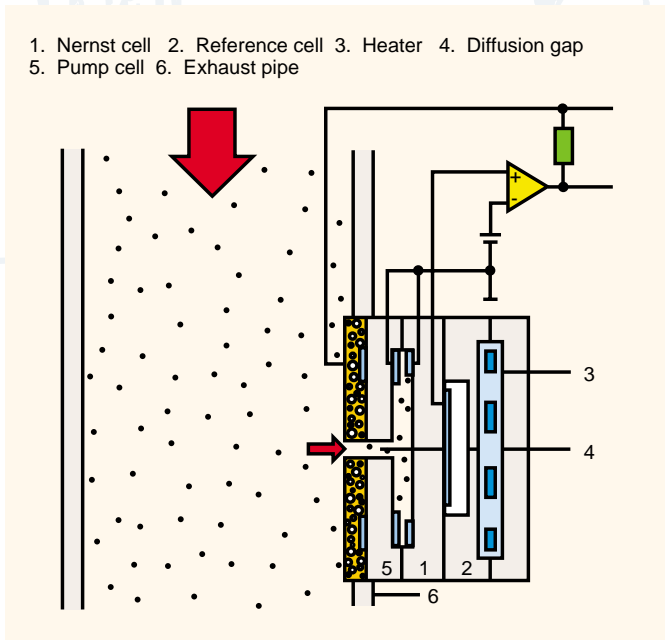

Figure 7. Design of a continuous action, wide-band oxygen sensor showing the sensor's installation in the exhaust pipe.

1. Mass airflow sensor
2. Engine
- 3a. Oxygen sensor 1
- 3b. Oxygen sensor 2
4. Catalytic converter
5. Injectors
6. Electronic control unit

Vv Valve control voltage Vs sensor voltage Qe injection quantity

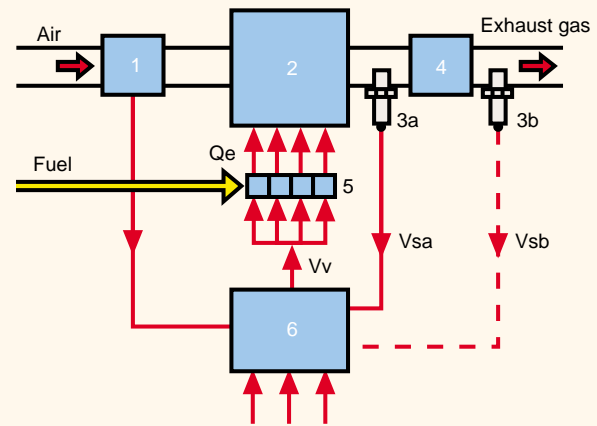

Figure 8. Diagram of closed λ closed-loop mixture control.

chamber (diffusion gap) in the Nernst cell. This configuration contrasts with the layout of the two-state sensor by maintaining a consistently stoichiometric air/fuel ratio in the chamber. Electronic circuitry modulates the voltage supply to maintain the composition of the gas in the monitoring chamber at a consistent λ equals one. The pump cell corresponds to lean exhaust by discharging oxygen from the diffusion gap to the outside, but reacts to rich exhaust by pumping oxygen from the surrounding exhaust gas into the diffusion gap, reversing the direction of the current. Because the pumping current is also proportional to the oxygen concentration and/or oxygen deficiency, it serves as an index of the excess air-factor of the exhaust gas. An integral heater unit ensures an operating temperature of at least 600°C.

The two-state unit uses the voltage at the Nernst cell as a direct measurement signal while the wide band sensor employs special processing and control circuitry to set the pumping current. This current is then monitored and measured as an index of the exhaust gas's excess-air factor. Because sensor operation is no longer dependent on the step function response of the Nernst cell, air factors ranging from 0.7 to 4 can be monitored as a continuous progression. Thus λ control of the engine can proceed on a reference spectrum instead of depending solely upon a single point.

Closed loop control

The oxygen sensor relays a voltage signal to the electronic engine management unit which then issues a command to the injection system to enrichen or lean out the mixture as indicated by the oxygen sensor's signal voltage (see Figure 8). The system thus counters lean mixtures by increasing the injected fuel quantity and rich mixtures by reducing it.

Information and illustrations for this article supplied by Bosch.

Interesting? Circle 11
Not interesting? Circle 12